



BUMA TEC CO., LTD.
BUMA Technical Compressor



High Efficiency Cost Saving Quiet Operation

BUMA SCREW AIR COMPRESSOR

Direct Drive Coupling Type BFD55

BUILT ON TRUST

BFD55

Specification

BUILT ON TRUST

Surrounding

Atmosphere ----- 760 mmHg
Working Pressure ----- 8.0 kgf/cm²
Max. Temperature ----- 46 °C

Compressor

Free Air Delivery ----- 9.6m³/min at 8.0 kgf/cm²

Cooling Method ----- Air Cooled by Cooling Fan
Outlet Air Temperature ----- Ambient Temp. +15°C
Operation Control
Driven Method ----- Direct Driven

Electric Motor

Rating Power ----- 55 kW (75Hp)
Power Source ----- AC380V/3-Phase (50Hz)
Start Method ----- Y-Δ
Pole / RPM ----- 2 pole / 2950 rpm
Service Factor ----- 1.2
IP Class ----- IP 54
Enclosing

Others

Oil Volume ----- 40 ℓ
Noise level ----- 75 dBA
Pipe connection ----- 50A
Dimension ----- 1700mm x 1200mm x 1520mm
Weight ----- 1800 Kg

Controller

Compressor Controller ----- Micro Controller
Power Source ----- AC380V, 3 Phase
(Built-in Transformer)
Pressure Control ----- Continuous Pressure Control
by Pressure Sensor
Control Method ----- Loading & Unloading Control
Operation Mode ----- • Automatic Mode
----- • Continuous Mode
----- • Remote Mode
----- • Schedule Mode
(Default: Automatic)

Error Detecting Function & Auto-Control Function (LCD & LED Display)

----- ♦ System Trip and Warning Function
- Outlet Air Temperature High
- Main Motor Overload
- Fan Motor Overload
- Pressure & Temperature Sensor Fault
----- ♦ Auto-Control Function
- Stop Delay Function
- Re-start Pressure
- Automatic Start

Maintenance Function (LCD & LED Display)

----- ♦ Air Filter Change Warning
----- ♦ Oil Filter Change Warning
----- ♦ Oil Separator Change Warning

Operation Status Display (LCD & LED Display)

----- ♦ Outlet Air Pressure
----- ♦ Outlet Air Temperature
----- ♦ Operation Mode
----- ♦ Load / Unload Status

Statistics Function

----- ♦ Amot Clock (Automatic Time)
----- ♦ Total Operating Hour
----- ♦ Load / Unload Hour
----- ♦ Set Stop Delay Time



The specifications of this machine are subject to change for improvements.

BFD55

Components

BUILT ON TRUST



Electric Motor x 1unit

Type	Y2-225M-2-55
Rated Power	55kw (75 HP)
Service Motor	1.3
Electric Source	AC380, 3-Phase, 50 Hz
Mode of Operation	S1, Continuous Operation Mode
Pole / RPM	2-Pole / 2940 rpm at 50Hz
Cooling Method	Built-in Fan Cooled
Lubrication	CHERROM
Starting Method	Start-Delta



Screw Airend x 1unit

Model	3.47.100001
Compression	Oil Flooded 1-Stage Compression
Rotor Combination	5 x 6 (Male * Female)
Pressure Range	5 ~ 13 bar
Operation Speed	2950 rpm



Suction Air Filter x 1unit

Model	BUMA Genuine Filter
Filtration grade	2 μm / Min. 99.8 % (3 ppm)

Lubrication Oil Circulation

Combined Cooler - Aluminum Wing Type Cooler (for Air / Oil Cooling)	1 unit
Oil Filter Housing	1 unit
Oil Filter (BUMA Genuine Filter)	1 unit
Oil Line - Seamless Tubing&O-ring Type Parker Fitting	1 set
Cooling Fan - Low Noise Centrifugal Fan	1 unit
Fan Motor (AC380V)	1 unit



Instrument Panel

Controller (BUMA Controller)	1 unit
Pressure Sensor - Pressure Range : 0 ~ 16 kgf/cm2 - Power Source : DC 24V - Analog Output : DC 0.1 ~ 10 V	1 unit
Temperature Sensor - Outlet Air Temperature	1 unit
Pressure Switch - No. 1: Detecting Compressor Sump Pressure - No. 2: Stand-by for Failure of Pressure Sensor	1 unit
Main EOCR - For Detecting Main Motor Overload	1 unit
Fan EOCR - For Detecting Fan Motor Overload	1 unit
Display LED (Trip) - Main Motor Overload - Discharge Air Temperature High	1 set
Display LED (Warning) - Filter Change - Discharge Temperature High	1 set
Operation Status - LED and Lamp Display (Mode, Load/Unload)	1 set
Start Box - Including Transformer and Converter - Control : DC24V, AC220V	1 set
Emergency Switch	1 unit



Pneumatic & Electric Valves

Intake Valve (HX DN85)	1 unit
Thermostatic Valve (DB LHGL-32C3)	1 unit
Minimum Pressure Valve (HX)	1 unit
Solenoid Valve - For Controlling Intake Valve and Purge Valve	1 unit
Safety Valve - A28X-16T (DN25)	1 unit
Purge Valve (HX)	1 unit

The specifications of this machine are subject to change for improvements.

BFD55

Appearance Drawing

BUILT ON TRUST

Unit: mm

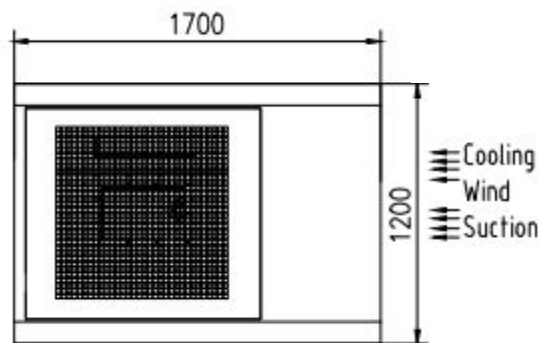
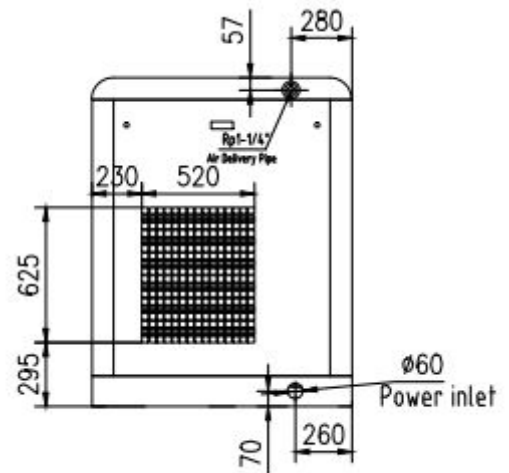
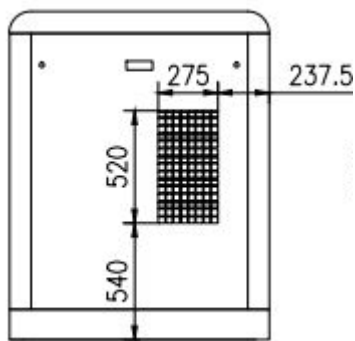

Dimension

Length : 1700 mm

Width : 1200 mm

Height : 1520 mm

Weight : 1800 Kg

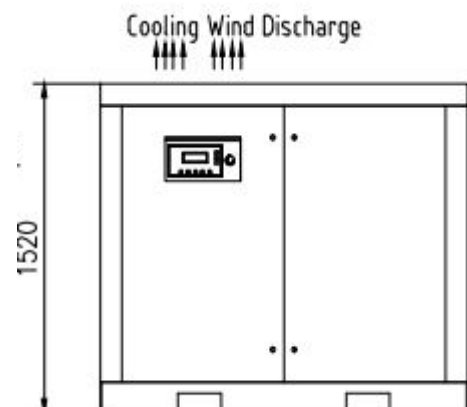
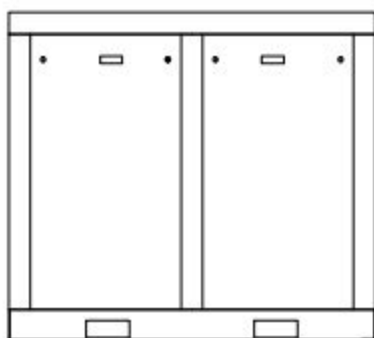

The specifications of this machine are subject to change for improvements.

BUILT ON TRUST

www.bumatec.com



BUMA TEC CO., LTD.

BUMA Technical Compressor

KOREA HEAD OFFICE

291 1637BEON-GIL, SEOBU-RO,
JUCHON-MYON,
GIMHAE-CITY, GYEONGNAM,
KOREA (621-843)

TEL: +82-55-337-9891~3

FAX: +82-55-337-9894

Email: bumace@bumace.com

CHINA FACTORY

WEST OF JIUJING ROAD,
DANYANG ECONOMIC
DEVELOPMENT ZONE,
JIANGSU, CHINA (Zip Code: 212300)

TEL: +86-551-6220030

FAX: +86-511-86220032

Email: buma@bumatec.com